

General Information

Project Name: _____

Consultant: _____

Item #: _____

Model #: _____

Quantity: _____



Specifications

TC2 Model Enclosed Carts are 18GA all welded transmitted body with 18GA double walled insulated doors. Heavy duty channel chassis is designed to absorb impact through casters and bumper frame. Doors are insulated and mounted on stainless steel hinges for 270 degrees swing back. Positive latch is mounted at each door.

Removable tray slides hold 15" x 20" or 14" x 18" trays (not furnished) from 20 to 40 total. Other size and quantity of trays can be accommodated also. Carts are provided with push handles and finished brush satin with coved edges.

Product Guide

Fully enclosed carts are designed for heavy-duty institutional use in tray delivery systems.

Doors swing back 270 degrees and held in open position by positive latch for service and cart washing.

Ease of cleaning is further improved with removable tray slides, pitched bottom and removable doors.

Options

- CS-8** - 8" Casters (In Lieu of 6" Casters)
- C-103** - Additional Casters (Set)
- DRL** - Door Lock
- DRS-107** - Doors on Back to Make Cart Pass Thru (Each)
- HDL-106** - Extra Handles (Each)
- GR-101** - Galley Rail
- INSD** - Insulated Doors (Each)
- WAB** - Wrap Around Bumpers





DRAWINGS

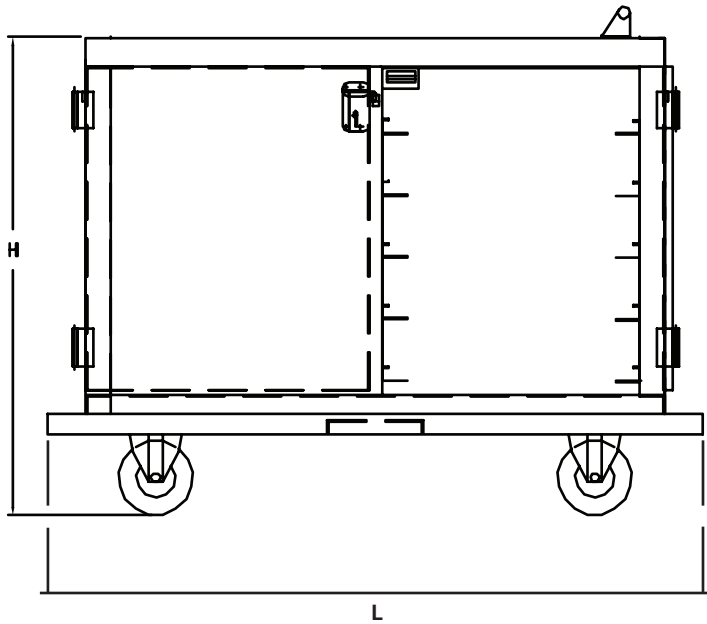

Front View

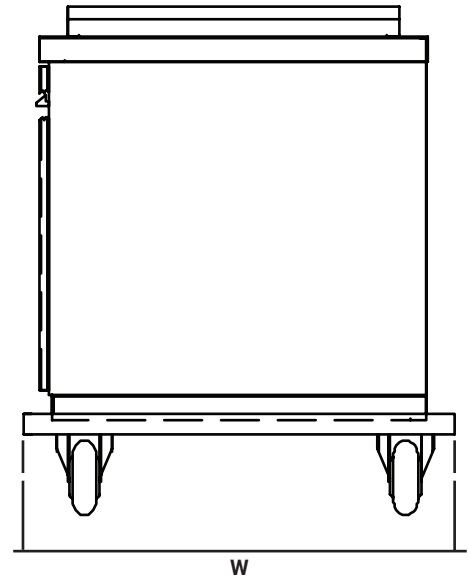

Side View

TRAY CART ENCLOSED CARTS

Model	Trays	Size (W x L x H)
□ TC2-20	20	35" x 53" x 38"
□ TC2-24	24	35" x 53" x 43"
□ TC2-28	28	35" x 53" x 48"
□ TC2-32	32	35" x 53" x 53"
□ TC2-36	36	35" x 53" x 58"
□ TC2-40	40	35" x 53" x 63"

Specifications subject to change without notice.

TC2-60 0324