

General Information

Project Name: _____

Consultant: _____

Item #: _____

Model #: _____

Quantity: _____



Model SHF-5-77

Specifications

Top: 16GA stainless steel type 300 series with 2" channel edge, all corners welded, ground and polished. S/S channel bracing provided as necessary.

Frame: 14GA Stainless steel multi-formed, fully welded vertical corner uprights.

Apron: 18GA stainless steel, 10" apron welded to framework.

Casters: 5" Heavy Duty ball bearing swivel casters, (2) with brakes.

Interlocking Device: As required, quick release latches are provided to join units together.

Heating Units: Each food well is pre-wired and provided with a 1200 watt element, thermostat control with pilot light and a 5' long cord.

Product Guide

Modular Hot Food Counters are electrically heated with individual controls. These functional units are designed to keep hot foods hot at your desired temperature levels. Heated drop-in pans can be used dry or wet and accommodate full size pans. Each well is provided with it's own thermostat control.

These sturdy units are designed for long lasting service. Units are provided with interlocking devices for quick and easy assembly and disconnecting.

Options

- Tray Slide (Solid) - 12" Wide
- Tray Slide (Three Bar) - 12" Wide
- Display Case (2-Tier)
- Protector Case
- Single Service Sneeze Guards
- Double Service Sneeze Guard
- Fluorescent Light
- Work Shelf
- Work Shelf w/ Poly Top
- Plate Shelf
- Full Front Panel (Laminate)
- Full End Panel (Laminate)
- Intermediate Undershelf
- Convenience Outlets - ____ (ea.)
- 14GA Top Upgrade
- Backsplash (6" High)
- Return Splash (6" High R/L)
- Laminate Doors
- Kick Base - Stainless Steel
- Correctional Package
- Sink - specify size: _____
- Lever Drain
- Legs w/ Bullet Feet
- Doors - Stainless Steel
- Lever Drain w/ Overflow
- Receptacle Bracket - ____ (ea.)
- Drawer(s) - ____ (ea.)
- Sound Deadended Top
- Infrared Heat Lamp



DRAWINGS

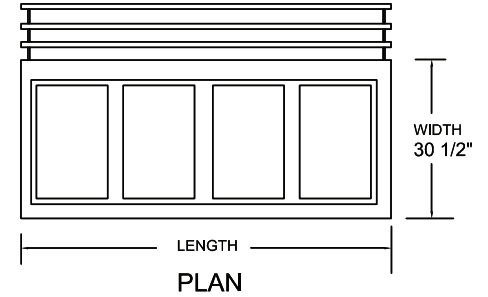
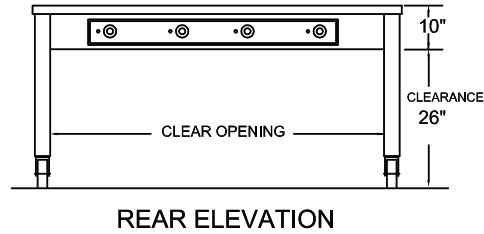
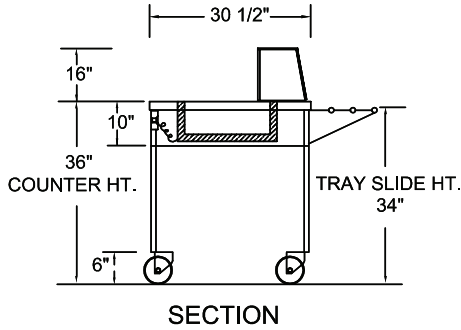

HOT FOOD COUNTER

Model	Size (W x L x H)	Description	Opening
□ SHF-2-35	30½" x 35" x 36"	2 Pans	26"
□ SHF-3-50	30½" x 50" x 36"	3 Pans	41"
□ SHF-4-63	30½" x 63" x 36"	4 Pans	53"
□ SHF-5-77	30½" x 77" x 36"	5 Pans	68"
□ SHF-6-92	30½" x 92" x 36"	6 Pans	40" (2)

RECOMMENDED COUNTER HEIGHT FOR SCHOOLS

- HIGH SCHOOL - STANDARD HEIGHT: 36" COUNTER HEIGHT - 34" TRAY SLIDE HEIGHT
- INTERMEDIATE SCHOOL: 34" COUNTER HEIGHT - 32" TRAY SLIDE HEIGHT
- ELEMENTARY SCHOOL: 32" COUNTER HEIGHT - 30" TRAY SLIDE HEIGHT

Specifications subject to change without notice.

SHF-50 0919