



**U.S. Patented Safety Illumination**  
US 9,827,689 B2

# BIZERBA

## Food Service

Bizerba GSP series slicers are certified to the new NSF/ANSI Standard 8-2017

## ... GSP H i 90-K12 series - manual safety slicer ...

### Award winning - safety illuminated dial!

- Energy Efficiency: 1/2 H.P. motor, 319 r.p.m.
- High Yield: Operating time, designed for permanent operation
- High Yield: Unique carriage-shifting design allows for the smallest end pieces, increased product yield
- High Yield: Widest product carriage for increased capacity
- High Yield: Heavy-duty, 3 lb. blade knife cover, durable
- High Yield: Debris deflector, permanently mounted, included
- High Yield: Precision machined pencil-point-grooves on gauge plate, blade cover and carriage to reduce friction, produce better looking product
- Safety Interlock: No-volt release
- Safety Interlock: Adjustable blade shut off settings: 15, 30, 45 seconds or off
- Safety Interlock: Shut off in slice thickness knob
- Safety Interlock: Carriage and gauge plate lock during the cleaning process
- Safety Interlock: Forced start with slice thickness knob below zero
- Operator Safety: Slicer installation, start-up and training, included
- Operator Safety: Illuminated index slicing dial, at-a-glance machine status:
  - green - safe for cleaning
  - flashing red - blade exposed, close gauge plate before cleaning
  - solid red - proceed with caution, ready to slice
- Operator Safety: Green push-handle on carriage, safe slicing
- Operator Safety: Red remnant-lift arm handle, reminds operator to use caution
- Operator Safety: 3.5"W (90mm) x 9.13"H x 2.6"D thumb guard wall for maximum protection
- Operator Safety: 360° blade enclosure, no top-gaps in blade ring-guard
- Operator Safety: Zero blade exposure during the cleaning process
- Operator Safety: Front mounted controls
- Operator Safety: Rear mounted lift arm with largest and easiest to use remnant holder with 306 holding points, removable for cleaning, dish-machine safe
- Operator Safety: Low profile carriage for easy loading of heavy product
- Operator Safety: Side lift arm for easy cleaning under slicer
- Operator Safety: Recommended 31.25" - above floor height
- Food Safety: One piece anodized aluminum construction
- Food Safety: Non-removable carriage system for faster cleaning and sanitizing
- Food Safety: Double-sided seal between blade knife and housing, no gap for food to collect, better hygiene
- Food Safety: UL157 dairy grade seals and gaskets used to seal against water and food debris, no silicone used under seals, better hygiene
- Food Safety: Liquid and debris diversion from all control surfaces
- Food Safety: Remote blade sharpener does not collect food debris during operation and is dishwasher safe for improved safety and hygiene
- Food Safety: One piece carriage with seamless thumb guard for highest hygiene standards, no slotted-screw heads on thumb guard
- K-12 School Two Year Warranty: On-site, labor and parts

### Best blade in the industry

The unique design of our blade produces clean and consistent slices. The hardness results in lasting sharp edge. The life of the blade is dramatically longer than the competition. Our st blade is the hardest, thinnest, largest, straightest blade in the industry.

- 13" diameter, chromium coated hard alloy
- 60-62 Rockwell hardness at the edge



BIM | CAD | MOBILE

Gauge plate closed, safe for cleaning - green.



Gauge plate open and motor running, ready to slice - solid red.



Model #: GSP H i 90-K12 | Stock #: 913003019

C.S.I. Division 11 | Section 400

Project Name: \_\_\_\_\_ AIA # \_\_\_\_\_

Location: \_\_\_\_\_ SIS # \_\_\_\_\_

Item Number: \_\_\_\_\_

Quantity: \_\_\_\_\_

# BIZERBA

## Food Service

### 1-phase AC current

- 120 V, specialised data available on request
- 60 Hz
- Frequency of nominal current 3.5 A
- Power consumption 0.360 kW

### Blade diameter

- 13" (330 mm)

### Blade speed

- 319 r.p.m.

### Max. produce size

- Height: 4.96" (126 mm)
- Width: 11.6" (290 mm)
- Round: 8" (200 mm)
- Rectangular: 11.6 x 6.4" (290 x 160 mm)

### Slice thickness

- 0-0.94" (0-24 mm), infinitely variable

### Thumb-guard rear wall

- 3.5"W x 11.13"H x 2.6"D (90 x 235 x 67 mm)

### Gravity-feed slicing carriage

- 40° inclined gravity feed

### H - Carriage inclination

- Carriage inclined 25° towards operator
- Carriage height positioned towards center of blade

### Noise control drive system

- 58.0 dB decibel level

### Installation area

- (L x W) 20.94" x 18.82" ( 530 x 480 mm)

### External dimensions

- (L x W x H) 28.54" x 23.07" x 23.46"
- 725 x 586 x 596 mm

### Operating area

- (L x W) 31.73" x 35.4" ( 806 x 899 mm)

### Food Safety - Ingress Protection type

- IP Solids level 3 | Liquids level 3

### Weight of machine

- 95.1 lbs, 43 kg

### Shipping Details & Dimensions

- Total Shipping Dimensions (L x W x H): 32.5" x 27.8" x 32" (826 x 706 x 813 mm)
- Total Shipping Weight: 124 lbs, 56.3 kg
- Cubic: Ft. 16.73, 0.47 m
- Density: 7.41 lb/cubic ft, 118.95 kg/cubic m

### Additional equipment

- Equipment Stand
- Food Chute and stomper
- Slaw tray
- SlicerGard™ Service Protection Plan, Full Service Contract from 12 to 60 months.
- 13" (330 mm) Grooved Cheese Blade



Remote sharpener, better food safety

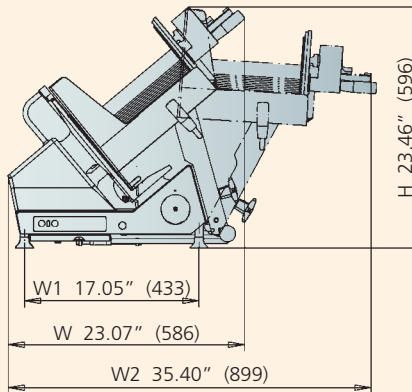
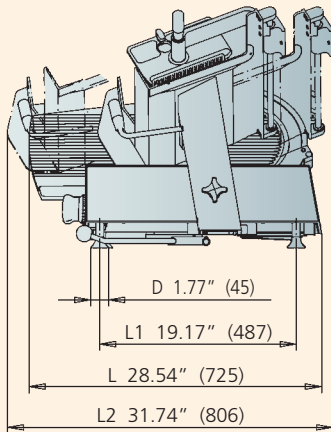

## K-12 School Two Year Warranty

The GSP H I 90-K12 Safety Slicer carries a two-year, on-site parts and labor warranty against any flaws in materials and workmanship. This period begins with the date of purchase and, provided the unit is used properly in accordance with our instructions, is in full effect for one year from that date. Any work to be performed under this warranty must be performed between the hours of 8:00 a.m. and 4:30 p.m. local time, Monday to Friday. Bizerba will not pay over-time charges for work performed other than during normal business hours. Accessories have a 30-day replacement or repair warranty for the period beginning on the date of purchase. Damages incurred in transit or from installation error, accident, alteration or misuse are not covered. Transit damages should be reported to the carrier immediately. Bizerba shall not be liable for any consequential, com-pensatory, incidental, or special damages. All warranty work must be performed by a factory authorized Bizerba Representative.

### Members of the Bizerba Group

Bizerba GmbH & Co. KG  
 Wilhelm-Kraut-Straße 65  
 72336 Balingen  
 Germany  
 Tel. +49 7433 12-0  
 Fax +49 7433 12-2696  
 marketing@bizerba.de  
 www.bizerba.com

Bizerba USA Inc.  
 1804 Fashion Court  
 Joppa, MD 21085  
 USA  
 Tel. Office +1 732 565-6000  
 Tel. Service +1 732 565-6001  
 Fax +1 732 819-0429  
 us.foodservice@bizerba.com  
 www.bizerba.com

Bizerba Canada Inc.  
 6411 Edwards Blvd.  
 Mississauga, Ontario L5T2PT  
 Canada  
 Tel. +1 888 240-3722  
 French Tel. +1 877 699-2199  
 Fax +1 905 816-0497  
 ca.info@bizerba.com  
 www.bizerba.ca

Bizerba de México, S.A. de  
 C.V. Av. Rio Mixcoac No. 157  
 Colonia Florida  
 01030 México, D.F.  
 México  
 Tel. +52 55 5663-1397  
 Fax +52 55 5663-1296  
 contacto@bizerba.com.mx  
 www.bizerba.com.mx

