



# BEVERAGE-AIR

Project: _____	AIA#
Item: _____	
Location: _____	SIS#
Approved: _____	

**ST34HC DUAL ACCESS, COLD WALL: SCHOOL MILK SERIES**

## SCHOOL MILK COLD WALL COOLER

### ST34HC Dual Access Cooler

### Hydrocarbon Series

**MODEL:**  
**ST34HC-W-02**



**5 Year Parts/Labor Warranty Available**  
**7 Year Compressor Warranty**

### CABINET CONSTRUCTION

- White coated steel exterior
- Stainless steel interior
- Stainless steel lids, hinged doors and door latches
- Dual sided access
- Full electronic control
- Heavy-duty epoxy coated steel wire floor racks standard
- Floor drain is centrally located for easy cleaning and connecting to drain hose with hose adapter
- Flexible compression door gaskets, ensures a tight seal
- Self-latching doors/lids with safety bumpers
- Exterior thermometer
- Cylinder locks
- 4" Heavy-duty plate casters (2 with locks)
- Cold wall milk coolers are designed to hold product temperature during service. Product should be removed at the end of service and moved to long-term, refrigerated storage

### OPTIONS & ACCESSORIES

- 3 Year parts/labor standard, additional 2 year warranty available
- Corner bumpers
- Cafeteria tray slides
- Graphics

### REFRIGERATION SYSTEM

- Uses environmentally friendly, energy efficient R290 refrigerant, and meets all regulatory requirements for CARB, SNAP, DOE & more
- Maintains product temperature between 36°F- 40°F



Please verify qualifying units by visiting:  
[www.energystar.gov/cfs](http://www.energystar.gov/cfs)

3779 Champion Blvd., Winston-Salem, NC 27105  
1-888-845-9800 Fax: 1-336-245-6453  
Beverage-Air.com Sales@bevair.com



# BEVERAGE-AIR

## School Milk Cooler - Dual Access

Model: ST34HC-W-02

MODEL	ST34HC-W-02
<b>EXTERNAL DIMENSIONAL DATA</b>	
Width Overall	34"
Depth Overall	31 ¼"
Height Overall with Casters	41 ⅞"
Number of Lids/Doors	Dual Access
Both Lids Extended	61"
<b>INTERNAL DIMENSIONAL DATA</b>	
NET Capacity (cubic ft.)	12.37
Internal Width Overall (in)	31"
Internal Depth Overall (in)	27"
Internal Height Overall (in)	25 ½"
<b>CASE CAPACITY</b>	
13" X 13" X 11"	8
19" X 13" X 11"	4
<b>ELECTRICAL DATA</b>	
Full Load Amperes	3.7
<b>REFRIGERATION DATA</b>	
Horsepower	1/2
Capacity (BTU/Hr)	1690
Heat Rejection (BTU/Hr)	2535
Charge (lbs/grams/ounces)	0.1544 / 70 / 2.5
<b>SHIPPING DATA</b>	
Gross Weight - Crated	290 lbs
Height - Crated	44"
Width - Crated	37"
Depth - Crated	33"

### Model Views

Required Clearance: 4 ¾" bottom

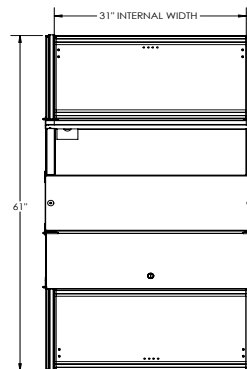

PLAN VIEW

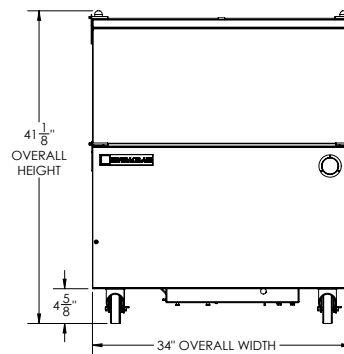

ELEVATION VIEW

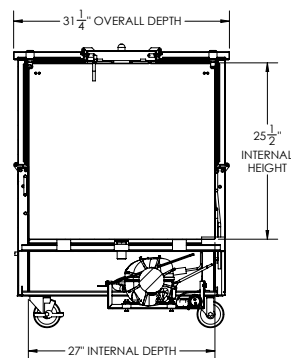

SIDE VIEW

### ELECTRICAL CONNECTION



115/60/1  
NEMA 5-15P

Unit pre-wired at factory and include 8' long cord and plug set.

