



# BEVERAGE-AIR

Project: _____	AIA#
Item: _____	
Location: _____	SIS#
Approved: _____	

**STF49HC DUAL ACCESS, FORCED AIR: SCHOOL MILK SERIES**

## SCHOOL MILK FORCED AIR COOLER

STF49HC Dual Access Cooler  
Hydrocarbon Series

**MODEL:**  
**STF49HC-1-W-02**



**5 Year Parts/Labor Warranty Available**  
**7 Year Compressor Warranty**

### CABINET CONSTRUCTION

- White coated steel exterior
- Stainless steel interior
- Stainless steel lids, hinged doors and door latches
- Full electronic control
- Dual sided access
- Heavy-duty epoxy coated steel wire floor racks standard
- Floor drain is centrally located for easy cleaning and connecting to drain hose with hose adapter
- Flexible compression door gaskets, ensures a tight seal
- Self-latching doors/lids with safety bumpers
- Exterior thermometer
- Cylinder locks
- 5" Heavy-duty plate casters (2 with locks)
- Balanced, forced-air refrigeration system provides rapid chilling of product

### OPTIONS & ACCESSORIES

- 3 Year parts/labor standard, additional 2 year warranty available
- Corner bumpers
- Cafeteria tray slides
- Graphics

### REFRIGERATION SYSTEM

- Uses environmentally friendly, energy efficient R290 refrigerant, and meets all regulatory requirements for CARB, SNAP, DOE & more
- Maintains product temperature between 36°F- 40°F



Please verify qualifying units by visiting:  
[www.energystar.gov/cfs](http://www.energystar.gov/cfs)

3779 Champion Blvd., Winston-Salem, NC 27105  
1-888-845-9800 Fax: 1-336-245-6453  
Beverage-Air.com Sales@bevair.com



# BEVERAGE-AIR

MODEL	STF49HC-1-W-02
<b>EXTERNAL DIMENSIONAL DATA</b>	
Width Overall	49"
Depth Overall	34"
Height Overall with Casters	47 3/4"
Number of Lids/Doors	Dual Access
Both Lids Extended	64"
<b>INTERNAL DIMENSIONAL DATA</b>	
NET Capacity (cubic ft.)	20.55
Internal Width Overall (in)	46"
Internal Depth Overall (in)	30"
Internal Height Overall (in)	24 5/8"
<b>CASE CAPACITY</b>	
13" X 13" X 11"	12
19" X 13" X 11"	8
<b>ELECTRICAL DATA</b>	
Full Load Amperes	2.46
<b>REFRIGERATION DATA</b>	
Horsepower	1/4
Capacity (BTU/Hr)	1851
Heat Rejection (BTU/Hr)	2776.5
Charge (lbs/grams/ounces)	0.1562 / 70 / 2.5
<b>SHIPPING DATA</b>	
Gross Weight - Crated	334 lbs
Height - Crated	55"
Width - Crated	54"
Depth - Crated	38"

## School Milk Cooler - Dual Access Model: STF49HC-1-W-02

### Model Views

Required Clearance: 4 3/8" bottom

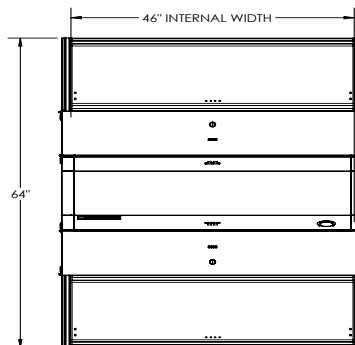

**PLAN VIEW**

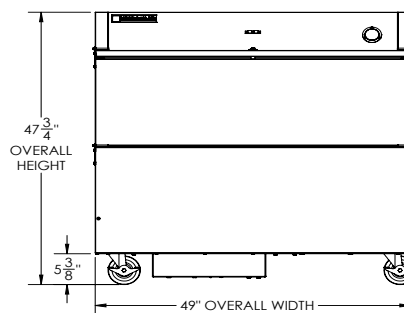

**ELEVATION VIEW**

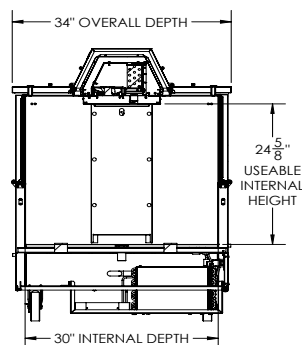

**SIDE VIEW**



### ELECTRICAL CONNECTION



115/60/1  
NEMA 5-15P

Unit pre-wired at factory and include 8' long cord and plug set.