



BEVERAGE-AIR

Project: _____	AIA#
Item: _____	
Location: _____	SIS#
Approved: _____	

PH2 P-SERIES WARMING CABINET

P-SERIES REACH-IN WARMING CABINET

PH2 Solid Half-Door Warming Cabinet

MODEL:
PH2-1HS



5 Year Parts/Labor Warranty Available

CABINET CONSTRUCTION

- Exterior stainless steel front and side (galvanized top, back and bottom)
- Interior liner is made of corrosion resistant aluminum
- Stainless steel interior door liner
- Stainless steel breaker caps
- Full electronic control
- Operational indicator panel contains thermometer and adjustable thermostat control which is accurately calibrated from 80°F to 180°F
- Manually controlled humidity vents are provided in the top of the cabinet
- Self-closing doors with 120° hold open feature, with cam-lift hinges
- Heavy-duty cylinder locks and self-adjusting magnetic gasket
- Six (6) silver freeze shelves
- 6" Legs
- 8' Cord and plug (see electrical data for details)

OPTIONS & ACCESSORIES

- 3 Year parts/labor standard, additional 2 year warranty available
- Pan slides
- Stainless steel interior
- 3" or 6" Casters
- Left or right door hinge (at time of order)

ELECTRICAL SYSTEM

- 20 AMP breaker required
- Strip type 750-watt heating elements, operating on 208-240/60/1, having a total of 1500 watts per compartment
- Externally mounted blower system maintains even temperature through out the food zone area



Please verify qualifying units by visiting:
www.energystar.gov/cfs

3779 Champion Blvd., Winston-Salem, NC 27105
1-888-845-9800 Fax: 1-336-245-6453
Beverage-Air.com Sales@bevair.com



BEVERAGE-AIR®

MODEL	PH2-1HS
EXTERNAL DIMENSIONAL DATA	
Width Overall	52 1/8"
Depth Overall with Handle	34 5/8"
Height Overall	84 1/8"
Number of Doors	4
Depth with Door Open 90°	57 5/8"
Door Openings (in)	21 1/2" x 24 3/4"
INTERNAL DIMENSIONAL DATA	
NET Capacity (cubic ft.)	43.3
Internal Width Overall (in)	48 1/8"
Internal Depth Overall (in)	26"
Internal Height Overall (in)	56 5/8"
Number of Shelves	6
ELECTRICAL DATA	
Amps	11.3/13.0
Cabinet Voltage	208-240/60/1
Total Wattage (Heaters & Fan @240V)	3000
SHIPPING DATA	
Gross Weight - Crated	460 lbs
Height - Crated	88"
Width - Crated	55"
Depth - Crated	39"

Top Mount Warming Cabinet Reach-In Model: PH2-1HS

Model Views

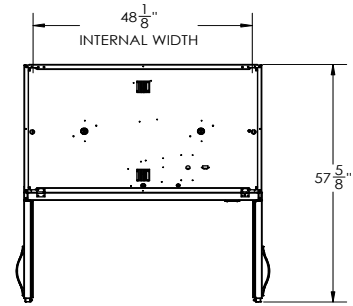

PLAN VIEW

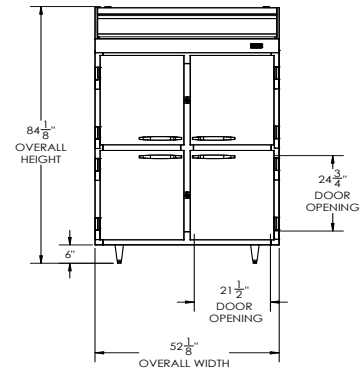

ELEVATION VIEW

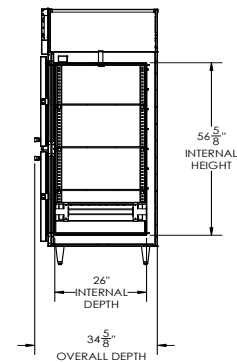

SIDE VIEW



ELECTRICAL CONNECTION



208-240/60/1
NEMA 6-20P

Unit pre-wired at factory
and include 8' long cord
and plug set.