

Item: _____	Model #: _____
Quantity (Qty): _____	Project: _____

G – Series Standard Oven Range Line 24" – 72" Series (Open Burners)

G24ST-24B | G36ST-36B | G482ST-48B | G602ST-60B | G722ST-72B



G482ST-48B

The Genesis Series range is the only range offering high-efficiency gas open burners today. The burner's unique design not only improves your cooking experience but significantly reduces gas waste as well. It is 100% manufactured from raw materials providing the best cooking experience, a high standard of quality, and the highest durability in its class to meet the needs of your commercial kitchen.

STANDARD FEATURES

RANGE

- 3-year parts and labor warranty.
- Patented high efficiency 2-piece cast iron non-clog & self-cleaning burners rated at 22,000 BTU (NAT) & (LP) p/ burner.
- 14 gauge fully welded interlocking frame.
- Chrome insulated knobs.
- 6" Adjustable legs.
- Conversion kit included.
- Stainless steel flex gas tube throughout.
- Stainless steel front and sides.
- Stainless steel removable crumb drawer under burners.
- Stainless steel 7" plate rail.
- Stainless steel 22.5" flue riser with a stainless steel reversible & removable over-shelf.
- One pilot light per burner.
- Heavy-duty 12" x 12" removable cast-iron grates.
- Front located manual gas shut-off to the entire range.

OVEN

- 30,000 BTU/h oven with snap action thermostat from 175 °F to 550 °F and 100% safety shut off.
- 26 1/2" Standard bakery depth on all ovens.
- Piezo spark ignition for oven bases.
- All stainless-steel oven cavity (Top, bottom, and side).
- Heavy-duty oven wired rack – 3/8" diameter.
- The standard oven has 4 shelf positions and 3 racks.
- Spring-assisted, Counterweight balanced doors.

OPTIONS & ACCESSORIES

- Modular pan rail accessory for 1/6 pans 24", 36", 48".
- Cutting Board 24", 36", 48".
- (4) 6" swivel casters with front locking brakes 24" & 36".
- (6) 6" swivel casters with front locking brakes 48", 60" & 72".
- Additional oven Rack.
- Quick disconnect (3/4 Flex hose quick disconnect 4' long with install kit).
- Stub Back Flue Riser 4" & 10".

CERTIFICATION:



AREA FOR CONSULTANT / CONTRACTOR:

G – Series Standard Oven Range Line 24" – 72" Series (Open Burners)

G24ST-24B | G36ST-36B | G482ST-48B | G602ST-60B | G722ST-72B

G – Series Standard Oven Range Line 24" – 72" Series (Open Burners)

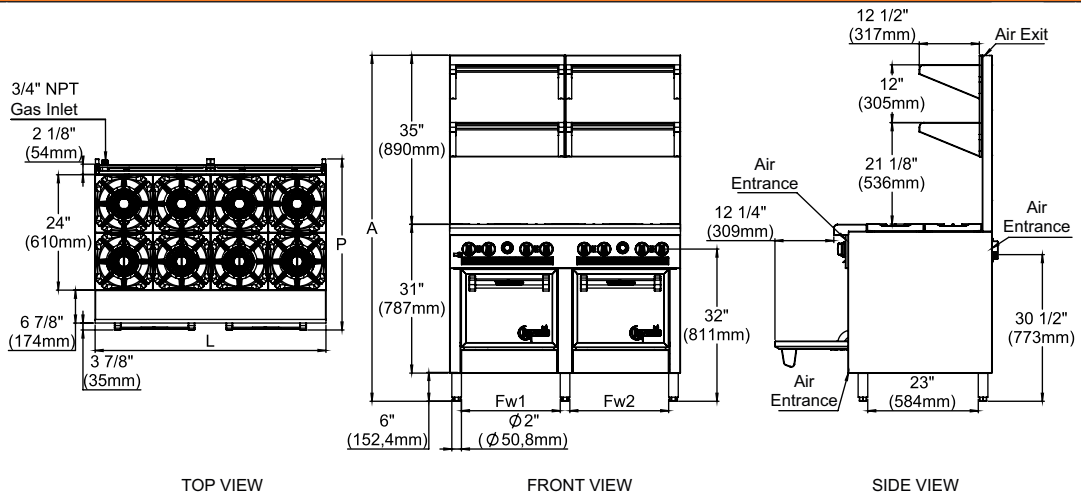

Models	Exterior Product Dimensions & Weight						Shipping Crate Dimensions & Weight				Oven - Inside				
	Width (L)	Depth (P)	Height (A)			Fw		Weight	Width	Depth	Height	Weight	Width	Depth	Height
			P.B	P.M	P.S	P.D	Fw1	Fw2							
G24ST – 24B	24" (610mm)						19 7/128" (484mm)		392 lb (178 kg)	28 5/32" (715mm)		456 lb (207 kg)	18 65/128" (470mm)		
G36ST – 36B	36" (915mm)						26 39/64" (676mm)		489 lb (222 kg)	40 1/32" (1017mm)	38 3/8"	613 lb (278 kg)	26 37/64" (675mm)		
G482ST – 48B	48" (1120mm)	34 19/64" (871mm)	39 49/64" (1010mm)	47 1/64" (1194mm)	60" (1524mm)	72" (1830mm)	20 71/128" (522mm)	20 71/128" (522mm)	805 lb (365 kg)	52 5/32" (1325mm)	44 3/32" (1120mm)	915 lb (415 kg)	18 65/128" - 18 65/128" (470mm - 470mm)	26 1/2" (673mm)	14 1/64" (356mm)
G602ST – 60B	60" (1525mm)						30 1/8" (765mm)	22 3/64" (560mm)	882 lb (400 kg)	64 1/32" (1630mm)		1069 lb (485 kg)	26 37/64" - 18 65/128" (675mm - 470mm)		
G722ST – 72B	72" (1830mm)						32 3/32" (815mm)	32 3/32" (815mm)	1060 lb (481 kg)	75 19/32" (1920mm)	50 1/32" (1271mm)	1237 lb (561 kg)	26 37/64" - 26 37/64" (675mm - 675mm)		

UTILITY INFORMATION

Models	Burners (Range)	Propane (BTU/h)	Natural (BTU/h)	Burners (Oven)	Propane (BTU/h)	Natural (BTU/h)	Manifold Pressure	
							Natural Gas	Propane Gas
							G24ST – 24B	4
G36ST – 36B	6	132,000	132,000	1	33,000	35,000		
G482ST – 48B	8	176,000	176,000	2	54,000	60,000		
G602ST – 60B	10	220,000	220,000	2	60,000	65,000		
G722ST – 72B	12	264,000	264,000	2	66,000	70,000		

*NOTE: The ovens of the model G482ST-48B and the Standard oven of the direct of the model G602ST-60B have thermal power of 27,000BTU/h (LP) and 30,000BTU/h (GN). The other oven models have a thermal power of 30,000BTU/h (LP) and 35,000BTU/h (GN).

SPECIFICATIONS

- Manifold pressure is 4"W.C (Natural Gas) or 10" W.C (Propane Gas).
- 3/4 "NPT rear gas connection and pressure regulator for both natural gas and propane.
- Check the altitude specifications above 2,000ft.
- *NOTE: In line with its policy to continually improve its product, Venancio USA reserves the right to change materials and specifications without notice.
- Specify the type of gas when ordering.
- Specify altitude when above 2,000 feet.

INTALLATION INSTRUCTIONS

A pressure regulator sized for this unit is included. The gas line connecting to the range must be 3/4" or larger. If flexible connectors are used, the inside diameter must be 3/4" or larger. An adequate ventilation system is required for commercial cooking equipment. Information may be obtained by writing to the National Fire Protection Association, 1 Batterymarch Park, Quincy, MA 02269, www.NFPA.org. When writing, refer to NFPA No. 96.4. These units are manufactured for installation in accordance with ANSZ223.1A (latest edition), National Fuel Gas Code. Copies may be obtained from The American Gas Association, 400 N Capitol St. NW, Washington, DC 20001, www.AGA.org.